

GUY WIRE FITTINGS

1. Wedge Clamp

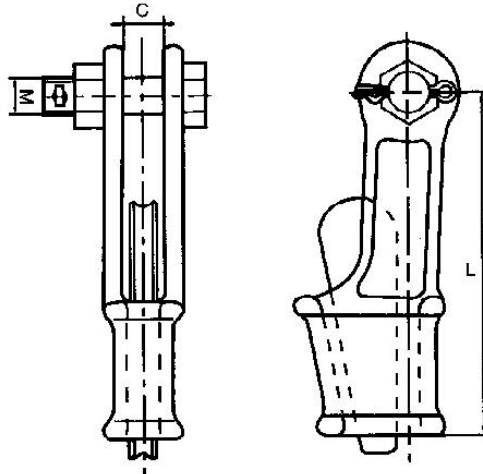

Catalog No.	Steel Wire Dia. (mm)	Dimensions (mm)			Rated Failure load (kN)	Weight (kg)
		C	M	L		
NX-1	6.6-7.8	18	16	150	45	1.2
NX-2	9.0-11.0	20	18	180	88	1.8

The body and wedge are made of malleable iron. The cotter pin is made of stainless steel. Other parts are made of steel. All ferrous parts are hot-dip galvanized.

2. Strain Clamp of Compression Joint (adjustable type)

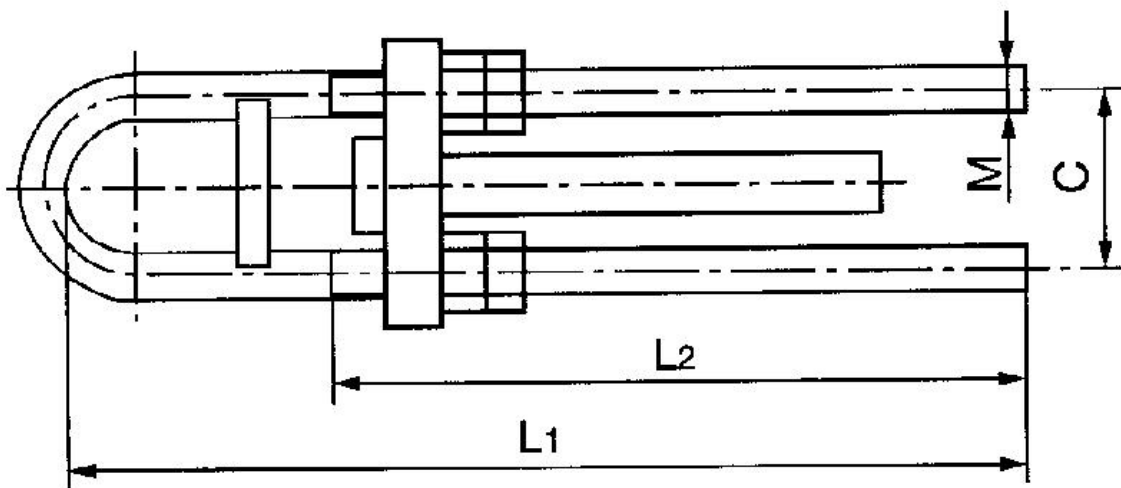

Catalog No.	Suitable Steel Wire	Dimensions (mm)				Rated Failure Load (kN)	Weight (kg)
		C	M	L ₁	L ₂		
NLY-50	1 x 7 - 9.0 – 140 - GB1200 -75	72	18	320	230	67.5	3.4
NLY-120	1 x 19 -14.0 – 155 - GB1200 -75	94	24	580	400	196.5	7.9
NLY-135	1 x 19 -15.0 – 155 - GB1200 -75	94	24	580	400	196.5	8.4
NLY-150	1 x 19 -16.0 – 155 - GB1200 -75	104	24	580	400	245.0	12.2
NLY-165	1 x 37 - 16.8 – 155 –GB1200 - 75	104	27	588	400	255.0	12.5
NLY-180	1 x 37 – 17.5 – 155 –GB1200 - 75	114	30	640	450	300.0	13.6
NLY-195	1 x 37 – 18.2 – 155 – GB1200 - 75	114	30	640	460	300.0	14.5
NLY-265	1 x 37 – 21.0 – 1570 – GB1200 - 75	128	36	670	440	367.0	26.6
NLY-100E	1 x 19 – 13.0 – 1570 – GB1200 - 88	84	22	490	300	151.0	6.3
NLY-125E	1 x 19 – 14.5 – 1570 – GB1200 - 88	94	24	580	380	188.0	9.1
NLY-150E	1 x 19 – 16.0 – 1570 – GB1200 - 88	104	27	610	400	228.0	12.0
NLY-180E	1 x 19 – 17.5 – 1570 – GB1200 - 88	114	30	640	420	273.0	15.6
NLY-240E	1 x 19 – 20.0 – 1570 – GB1200 - 88	128	36	670	440	357.0	22.6

Made of hot-dip galvanized steel. Tnti-steel equipment can be supplied if needed.

3. UT Wedge Clamp (adjustable type)

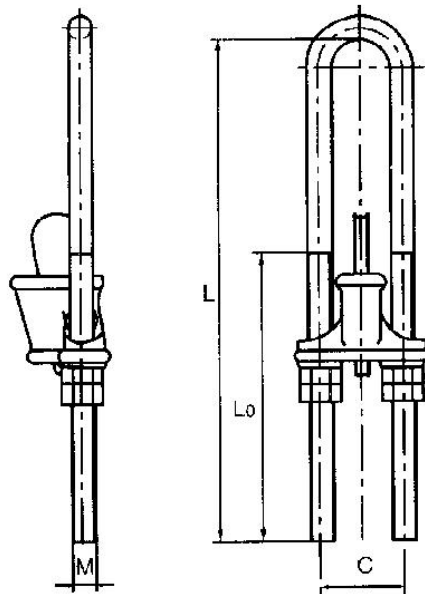

Catalog No.	Steel Wire Dia. (mm)	Dimensions (mm)				Rated Failure Load (kN)	Weight (kg)
		M	L	L ₀	C		
NUT-1	6.6-7.8	16	350	200	56	45	2.1
NUT-2	9.0-11.0	18	430	250	62	88	3.2
NUT-3	13.0-14.0	22	500	300	74	143	5.4
NUT-4	15.0-16.0	24	580	350	82	164	7.2

The body and wedge are made of malleable iron, other parts are made of steel. All ferrous parts are hot-dip galvanized. Tnti-steel equipment can be supplied if needed.

4. Shackle

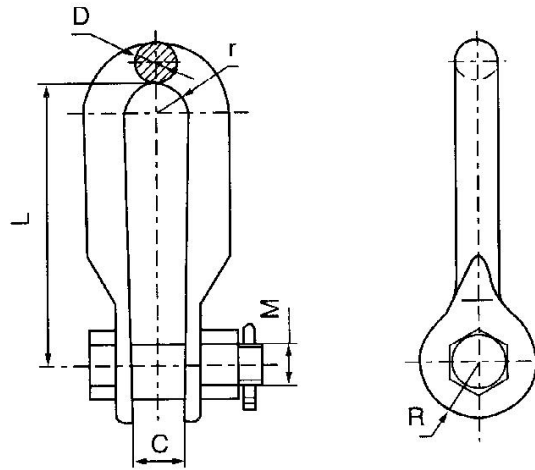

Catalog No.	Dimensions (mm)						Rated Failure Load (kN)	Weight (kg)
	C	M	D	L	r	R		
UL-7	20	16	16	120	15	22	70	0.7
UL-10	22	18	18	140	17	24	100	0.9
UL-16	26	24	22	140	19	32	160	1.6
UL-20	30	27	24	160	22	36	200	2.9

The cotter pin is made of stainless steel, other parts are made of hot-dip galvanized steel.

5. Strap

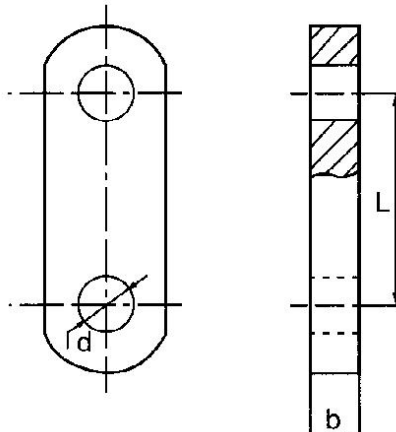

Catalog No.	Dimensions (mm)			Rated Failure Load (kN)	Weight (kg)
	b	d	L		
PD-7	16	18	70	70	0.5
PD-10	16	20	80	100	0.7
PD-12	16	24	100	120	0.9
PD-16	22	26	130	160	1.4
PD-30	32	39	120	300	3.9
PD-50	38	45	130	500	7.0

Made of hot-dip galvanized steel.

6. Anti-Steel Strain Clamp (NUTF type)

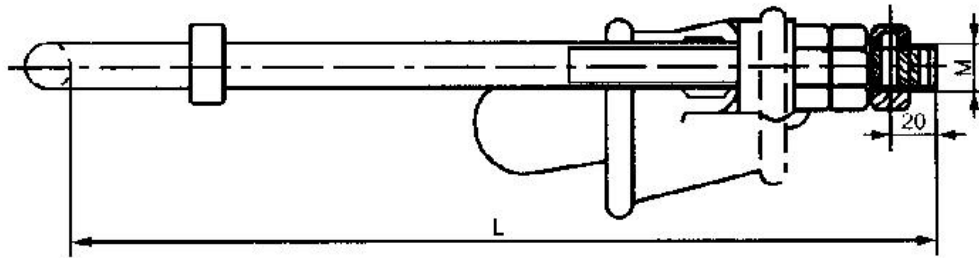

Catalog No.	Steel Wire Dia. (mm)	Dimensions (mm)		Failure Load (kN)	Weight Kg)
		M	L		
NUTF-1	6.6-7.8	16	350	45	2.1
NUTF-2	9.0-11.0	18	430	88.2	3.2
NUTF-3	13.0-14.0	22	500	143	5.5
NUTF-4	15.0-16.0	24	580	164	7.2

Made of hot-dip galvanized steel.

7. Turnbuckle Stay Rod

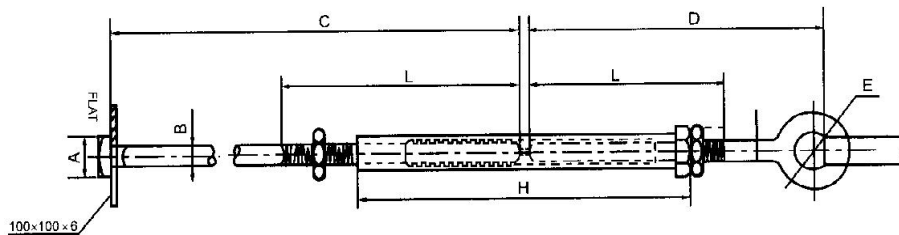

Catalog No.	Dimensions (mm)							U.T.S. (kN)	Weight (kg)
	A	B	C	D	E	H	L		
CH-16	30	16	2000	314	22	350	230	54	5.2
CH-18	35	18	2440	321	25	405	230	65	7.9
CH-22	35	20	2440	325	25	400	230	85	8.8
CH-24	40	22	2500	334	30	400	230	110	10.5

Made of hot-dip galvanized steel.

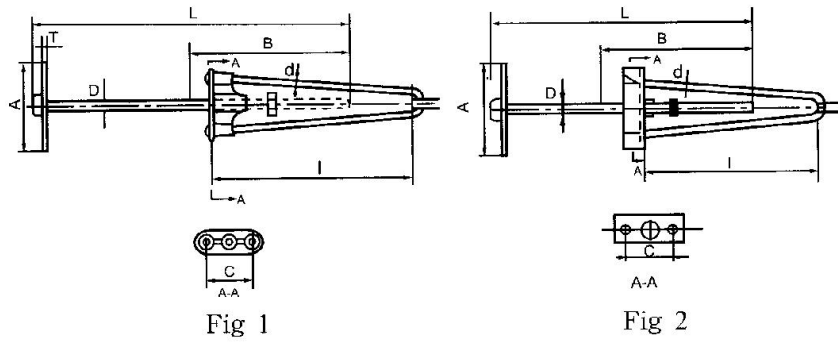

Catalog No.	Fig. No.	Dimensions (mm)								Rated Failure Load (kN)	Weight (kg)
		L	I	D	d	A	B	C	T		
LZ-18/180	1	1800	400	18	12	300	305	98	6	65	1.4
LZ-22-240	1	2400	400	22	14	380	305	110	6	96	17.9
LC-18/180	2	1800	300	18	12	300	305	98	6	65	13.8
LC-22/240	2	2400	380	22	14	380	305	110	6	96	17.0

Made of hot-dip galvanized steel.

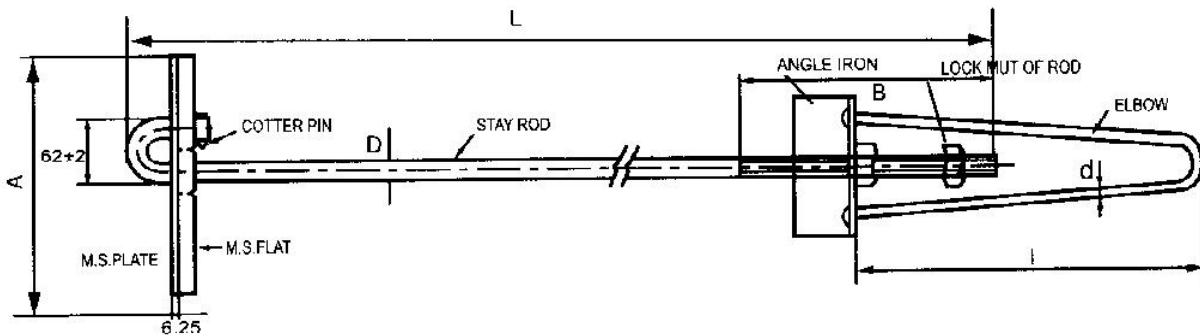

Catalog No.	Dimensions (mm)						Rated Failure Load (kN)	Weight (kg)
	L	I	D	d	A	B		
LJ-18/220	2000	300	18	14	300	100	65	9.9
LJ-22/250	2500	350	22	16	300	120	95	12

Made of hot-dip galvanized steel.

8. Thimble Clevis

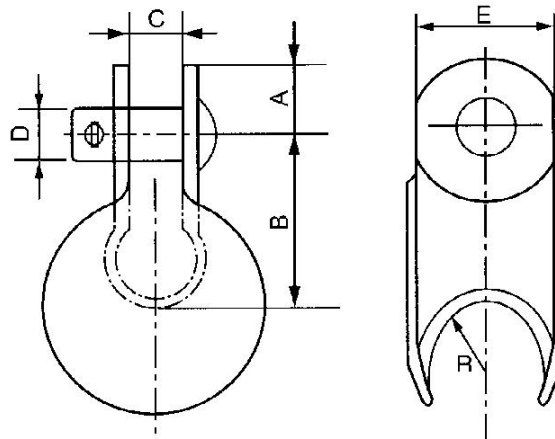

Catalog No.	Dimensions (mm)						Weight (kg)
	A	B	C	D	E	R	
XG-7A	25	54	19	12	40	26	0.49
XG-7B	25	54	19	16	40	35	0.55

Made of hot-dip galvanized steel.

9. Anchor Rod

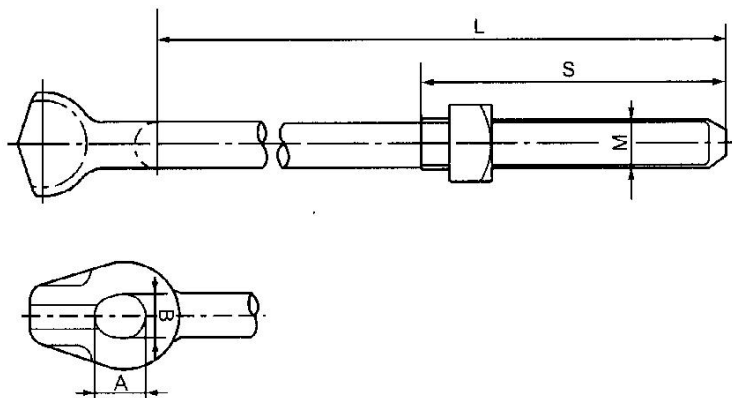

Catalog No.	Dimensions (mm)					U.T.S (kN)	Weight (kg)
	M	L	S	A	B		
XLZ-01B	16	203	102	17.5	14.3	56	0.35
XLZ-02B	16	254	102	17.5	14.3	56	0.40
XLZ-03B	16	305	152	17.5	14.3	56	0.50
XLZ-04B	20	254	102	20.6	17.5	60	0.90
XLZ-05B	20	305	152	20.6	17.5	60	0.95

Made of Drop forged steel, hot-dip galvanized steel.

10. Wedge Type Dead End Clamp

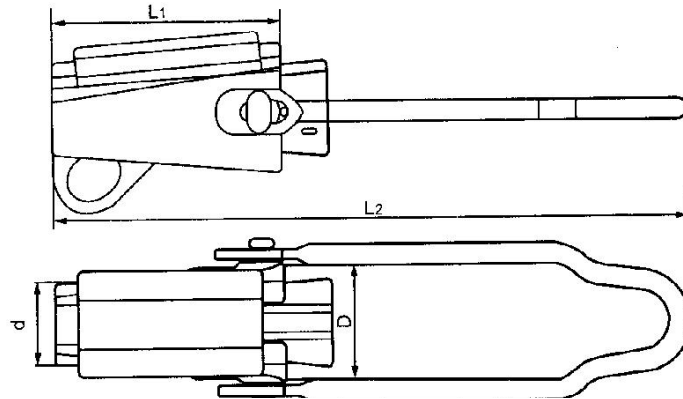

Catalog No.	Suitable Conductor, mm ²	Dimensions (mm)				(N)	(N)	Weight (kg)
		L ₁	L ₂	D	D			
TW-50	LJ-50	130	366	58.12	50.00	5600	7011	0.65
TW-70	LJ-70	130	366	58.12	50.00	82800	10354	0.65
TW-95	LJ-95	130	366	58.12	50.00	10982	13727	0.65
TW-120	LJ-120	130	366	58.12	50.00	13900	17339	0.85
TW-150	LJ-150	130	366	58.12	50.00	16800	21033	0.85
TW-185	LJ-185	144	380	64.52	54.45	21400	26732	1.05
TW-240	LJ-240	144	380	64.52	54.45	27800	34679	10.5

Used for Aerial Bundled Cable (ABC)

11. Wedge Type Dead End Clamp

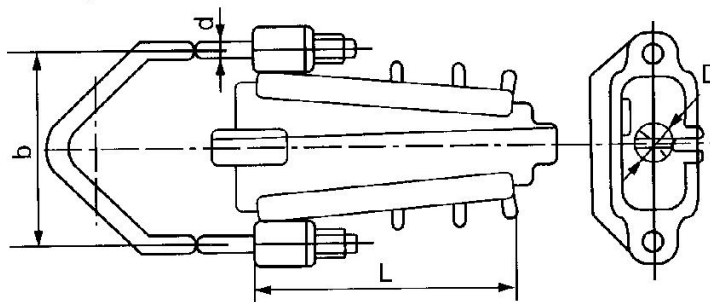

Catalog No.	Suitable Conductor, mm ²	Dimensions (mm)				Weight (kg)
		b	D	D	L	
NJX-1	JKLYJ-240	128	12	27	170	2.0
NJX-1	JKLYJ-185	128	12	27	170	2.0
NJX-2	JKLYJ-240	128	12	23	170	2.0
NJX-2	JKLYJ-120	128	12	23	170	2.0
NJX-3	JKLYJ-95	108	12	20	160	1.6
NJX-3	JKLYJ-70	108	12	20	160	1.6
NJX-3	JKLYJ-50	108	12	20	160	1.6

Used for Aerial Bundled Cable (ABC). The body is made of aluminum alloy, the wedge is made of UV resistant plastic. Others are made of hot-dip galvanized steel.

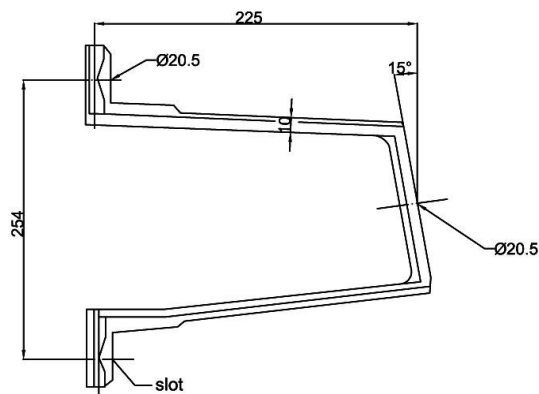
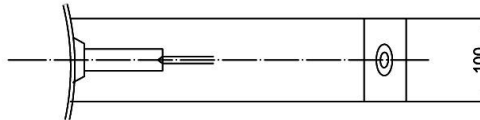
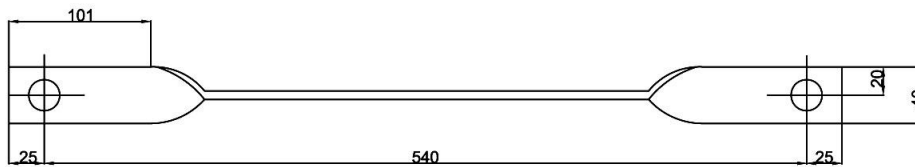
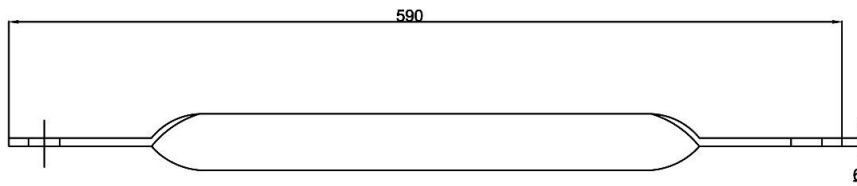
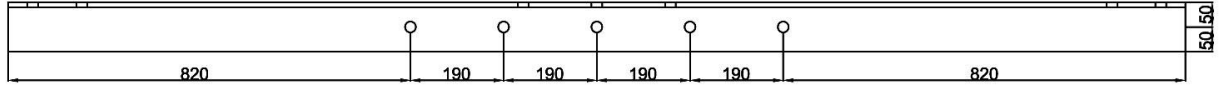
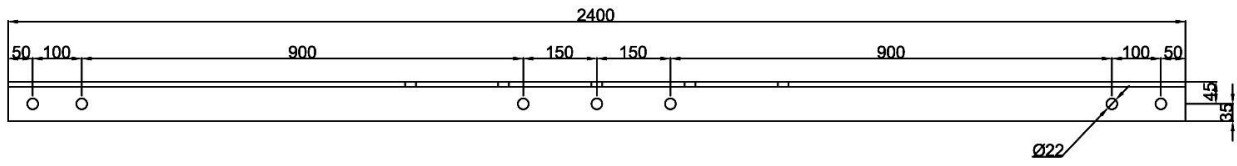

Various kind of structure fittings as per customers' need.